



QuadBarTM Ionizer

MODEL 4630

Simco-Ion's QuadBar Ionizer Model 4630 is the first corona ionizer to provide safe, effective static charge control in the ambient air inside a process chamber. Its unique quadropole configuration ensures effective ionization as close as 3 inches (7.6 cm) from the product. The 4630's compact size is designed to fit easily into the tight confines of any process equipment, and its ability to run on 24 VDC input power means it can connect to a tool's power source. In the rare event of a system failure, the QuadBar's status output notifies the process tool controller or a Facilities Monitoring System (FMS).

Simco-Ion developed the QuadBar to be the cleanest ionizer of its kind. When powered by 24 VDC, the QuadBar meets ISO 14644-1 Class 1 cleanliness levels..

Features

- Quadropole configuration with IsoStat[®] technology
- Compact size
- 24 VAC or 24 VDC operation
- Available with single crystal silicon emitter points
- Alarm output to FMS or process tool controller

Benefits

- Provides fast discharge and stable balance at distances as close as 3 inches (7.6 cm) from the product
- Fits into the tight confines of any process tool
- Connects to a 24 VAC or 24 VDC power supply or operates with Ion controller or small transformer
- Emitter points provide the cleanest emitter point material for ionization, meeting ISO 14644-1 Class 1 standards when operated with 24 VDC power, and ISO 14644-1 Class 2 standards when operated with 24 VAC power.
- Ensures immediate notification of catastrophic system failure



Specifications

Model 4630 QuadBar	
Ion Emission	Steady-state DC
Emitter Points	Single crystal silicon standard, field-replaceable, 2-3 year estimated life
Coverage Area	12" x 12" (30.5 x 30.5 cm)
Cleanliness	ISO Class 1 when powered with 24 VDC; ISO Class 2 when powered with 24 VAC with transformer or Model 4030 Controller
Airflow	80-100 fpm recommended.
Input Power	24 VAC, 35 mA via 14-1535 transformer, Model 4030 controller or properly grounded 24 VAC power supply; or 24 VDC power from tool power supply (but with reduced ion output)
Indicators	Green LED indicates power; red LED indicates alarm
Ion Balance	±50V @ 6" and 12" (30.5 cm) directly under the emitter points with airflow (80-100 fpm)
Discharge	<30 sec @ 12" (30.5 cm) directly under the emitter points with airflow (80-100 fpm)
Status Output	Model 5090 FMS interface attachment; Model 4030 controller signals OK or system failure
Materials	ABS enclosure
Mounting	Can be mounted to any process tool or flowhood using 4 #6 screws
Daisy-chain	Up to 4 units via 14-1535 transformer; up to 16 units via Model 4030 controller
Operating Environment	Temperature 15-50°C (59-122°F) recommended; relative humidity 20-65%
Maintenance	Emitter point cleaning at monthly to quarterly intervals, depending on environment; no adjustment or calibration required
Dimensions	1.3H x 1.3W x 3.6L in. (3.3 x 3.3 x 9.1 cm)
Weight	3.44 oz (100.3g)
Warranty	Two year limited warranty
Certifications	 RoHS Compliant
14-1535 Transformer	
Input Characteristics	100/115/230 VAC ±10%, 50/60 Hz, 35W
Output Characteristics	V (max), 29.5 VAC (no load); V (min), 26.0 VAC ±5% (full load); 0 to 1.0A
Temperature Range	0 to 122°F (50°C)

Ordering Information

91-4630EUR	QuadBar Ionizer
91-4030R	QuadBar Controller
14-1535	Transformer for QuadBar
33-1720-x	Interconnect Cable for QuadBar available in a variety of lengths from 4 inches to 15 feet where x indicates the length in feet. Standard cable included with bar is 6 feet.

BONDLINE
STATIC CONTROL SOLUTIONS

www.bondline.com.au
Tel: (02) 9757 3590

IsoStat Technology

Simco-Ion's IsoStat technology guarantees intrinsically balanced ionization and eliminates complicated feedback circuits. Ionizers incorporating this technology never need calibration and require very little maintenance. IsoStat is based on a law of physics, Conservation of Charge, which states that charge cannot be created or destroyed in an isolated system. By isolating the ionizer's emitter points from ground, IsoStat ensures equal numbers of positive and negative ions to better protect sensitive product.

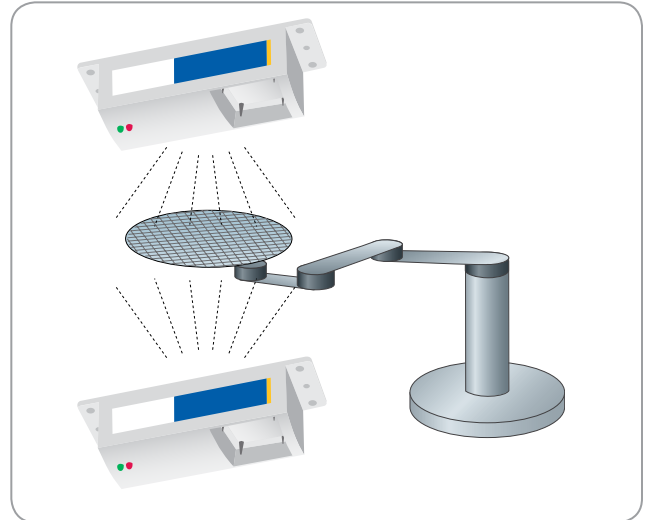

QuadBar ionizers placed above and below the wafer accelerate discharge times on the front and back surfaces, regardless of airflow.

Power Flexibility

A number of different options exist for powering the QuadBar. These include the QuadBar Controller Model 4030, which powers up to four QuadBars at once, connection to a properly grounded 24 VAC power supply, or connection to a 24 VDC tool power supply (although with reduced ionization output). The power choices available for the QuadBar are designed to accommodate varying installation sizes and power needs, making the QuadBar a versatile and effective ionizer.

SIMCO ION™
An ITW Company

DS-4630_V6 - 06/11
© 2011 Simco-Ion
All rights reserved.

Simco-Ion

Technology Group
1750 North Loop Rd., Ste 100
Alameda, CA 94502

Tel: 800.367.2452 (in USA)
Tel: 510.217.0600

info@simco-ion.com
www.simco-ion.com